

Grace/Crystal Installation Instructions

When connecting any electrical component please take note of the polarity. Wiring incorrectly may cause component failure.

Wire Preparation - Using stranded 20AWG wire, strip 3/16 of insulation from the wire ends. Exposing an excessive amount of wire may cause shorts.

Power Supply - 15v DC regulated low voltage
ALWAYS FOLLOW LOCAL ELECTRICAL CODES

Hard wire -

- Connect "AC IN" side of the power supply to an acceptable AC power source.
- Connect the "RED +" wire from the "DC OUT" side of the power supply to the "+" (Marked in RED) terminal of the fixture.
- Connect the "Black -" wire from the "DC OUT" side of the power supply to the "-" (UNMARKED) terminal of the fixture.

Wall Plug - Plug a suitable wattage size wall adapter into an AC powered outlet. Use supplied DC Jack adaptor with wires to connect to fixture being careful to match up the (+) power path marked in RED.

Fixture Wiring Configurations

Fixtures utilize 15v DC regulated low voltage power supplies. They can be wired in a Daisy Chain configuration or a Home Run configuration depending on your installation needs.

Fixture Wing Configurations

Fixtures wings can be removed for further flexibility of installation requirements. When removing both wings an industrial adhesive is required.

Fixture Mounting

For optimum performance surface mount the fixture towards the front of the cabinet. Adjust position to suite your installation requirements. **Use adhesive tape on the fixture to temporarily secure in place. Permanently secure with supplied self-tapping screws through the fixture wing.**

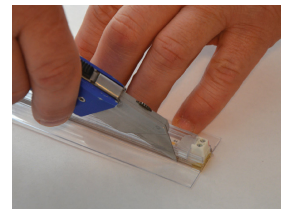
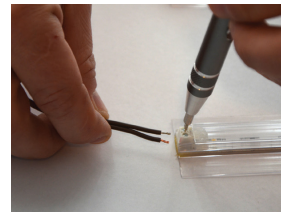
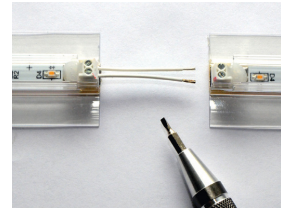

ENCLOSURE OPTIONS

Standard (Clear)
Offers the widest light pattern for maximum coverage.

Side Shield (Black)
Shield only reduces one side of the light pattern.

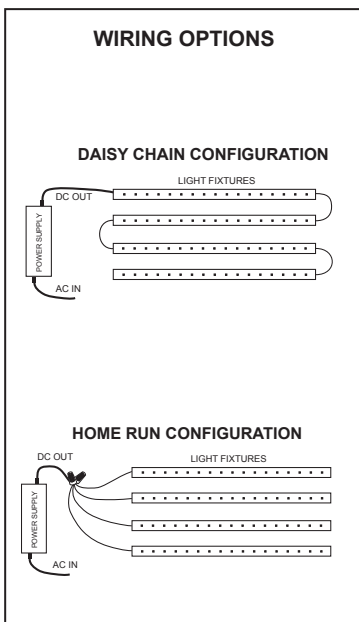

MAXIMUM DAISY CHANGE END TO END RUN

LBT	12ft.
LBQ	20ft.
LBI	30ft.
CBT	16ft.

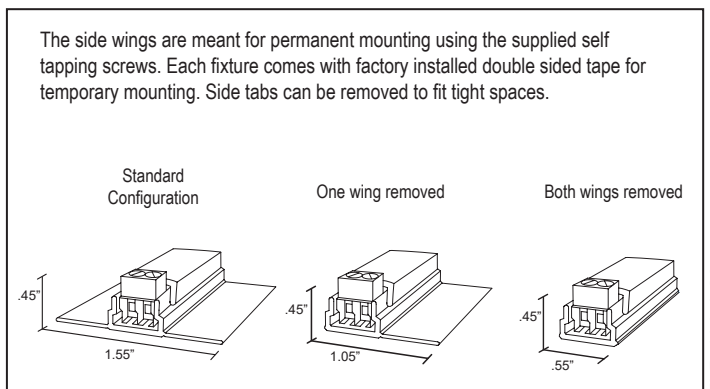
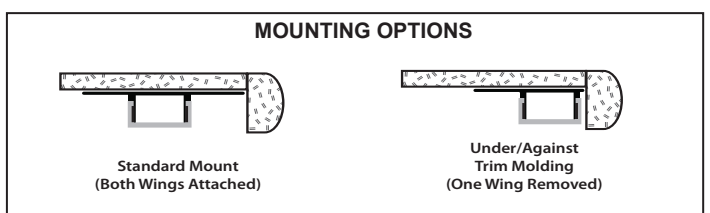
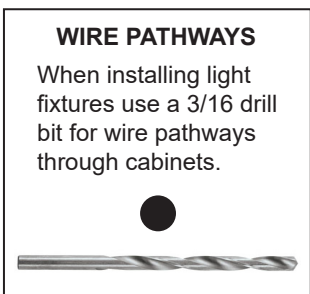

Grace Puck Installation Instructions

When connecting any electrical component please take note of the polarity. Wiring incorrectly may cause component failure.

Wire Preparation - Using stranded 20AWG wire, strip 3/16 of insulation from the wire ends. Exposing an excessive amount of wire may cause shorts.

Power Supply - 15v DC regulated low voltage
ALWAYS FOLLOW LOCAL ELECTRICAL CODES

Hard wire -

- Connect "AC IN" side of the power supply to an acceptable AC power source.
- Connect the "RED +" wire from the "DC OUT" side of the power supply to the "+" (Marked in RED) terminal of the fixture.
- Connect the "Black -" wire from the "DC OUT" side of the power supply to the "-" (UNMARKED) terminal of the fixture.

Wall Plug - Plug a suitable wattage size wall adapter into an AC powered outlet. Use supplied DC Jack adaptor with wires to connect to fixture being careful to match up the (+) power path marked in RED.

Fixture Wiring Configurations

Fixtures utilize 15v DC regulated low voltage power supplies. They can be wired in a Daisy Chain configuration or a Home Run configuration depending on your installation needs.

Fixture Mounting

For optimum performance mount the fixture towards the front of the cabinet. Adjust position to suite your installation requirements. Permanently secure with supplied screws.

NOTE: It's important to maintain power wire/terminal orientation when adding additional fixtures. Not doing so may cause fixture failure.



Through Surface Wiring



Surface Wiring

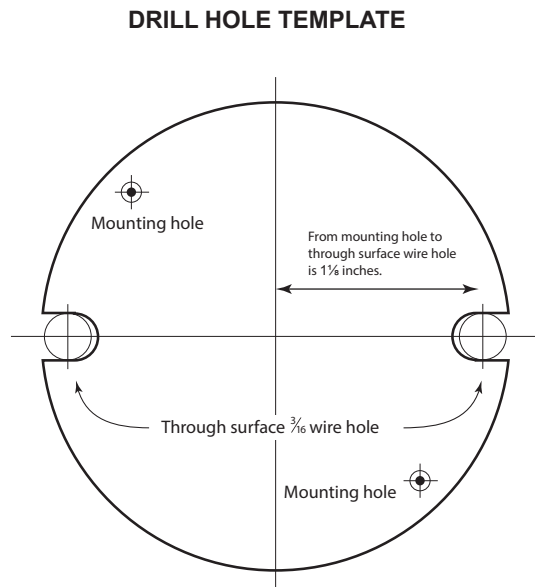
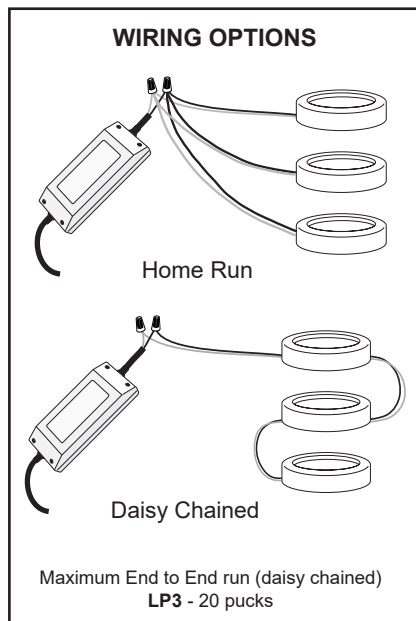
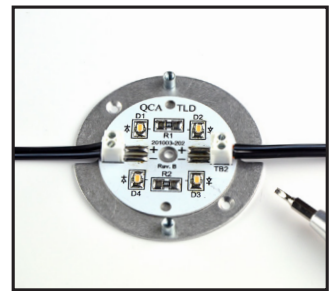

The Lighting Division



Life In LED Light

100 Boxart Street • Suite 230
 Rochester, NY 14612
 585-697-0093
 Fax: 585-663-1432
thelightingdivision.com



Made In USA
 of U.S. and
 imported parts

TLD-114-4-20